

PART.NO.:
DDR003-S5401-**

08: 1U"
09: 3U"
10: 5U"
11: 10U"
12: 15U"
13: 30U"

MATING:① INSETTING(25) → ② ROTATING → ③ FIXED
UNMATING:④ INSETTING(25) → ⑤ ROTATING → ⑥ WITHDRAWING

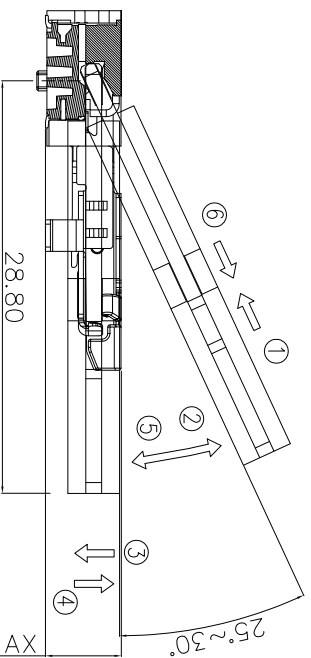

NO	DESCRIPTION	QTY	MATERIAL	PLATING & COLOR
G	FIXED-B	1	SUS304 0.35T	
F	FIXED-A	1	SUS304 0.35T	Matt Tin plating All Over 120u"Min
E	LATCH-B	1	SUS304 0.35T	
D	LATCH-A	1	SUS304 0.35T	Clear
C	TERMINAL-B	131	C5210 0.15T	Contact area gold plating Solder
B	TERMINAL-A	131	C5210 0.15T	TAIL G/F Ni 50u"Min Underplate
A	HOUSING	1	LCP,UL94V-0	BLACK.
				PLATING & COLOR

GENERAL	TOLERANCE	DWG.NO.	DDR003-S5401-08	PART.NO.	DDR003-S5401-**	DRAWN	DU 2023-06-14	UNIT	mm	SCALE	ND SCALE
---------	-----------	---------	-----------------	----------	-----------------	-------	---------------	------	----	-------	----------

X.±0.50	X.±5°	REV.	A4	TITLE	1 DF 4	CHECKED	APPROVED
---------	-------	------	----	-------	--------	---------	----------

X.±0.25	.X.±2°	SIZE	A4	SHEET	1 DF 4	APPROVED
---------	--------	------	----	-------	--------	----------

.XX±0.15	.XX±1°	1	2	3	4	5	6	7	8	9
----------	--------	---	---	---	---	---	---	---	---	---

REV.	ECN.NO.	MODIFY CONTENT
A		NEW
B	N23060601	CHANGE LATCH AND FIXED

REV.	ECN.NO.	MODIFY CONTENT
A		NEW
B	N23060601	CHANGE LATCH AND FIXED

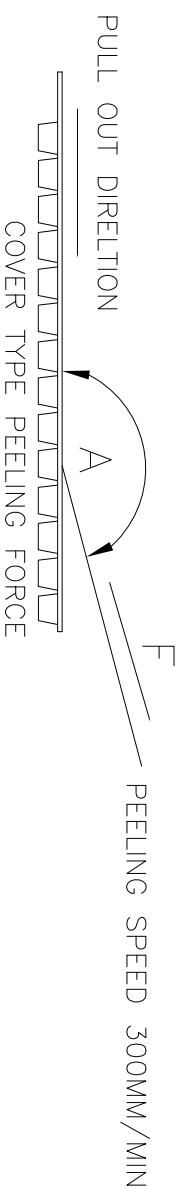
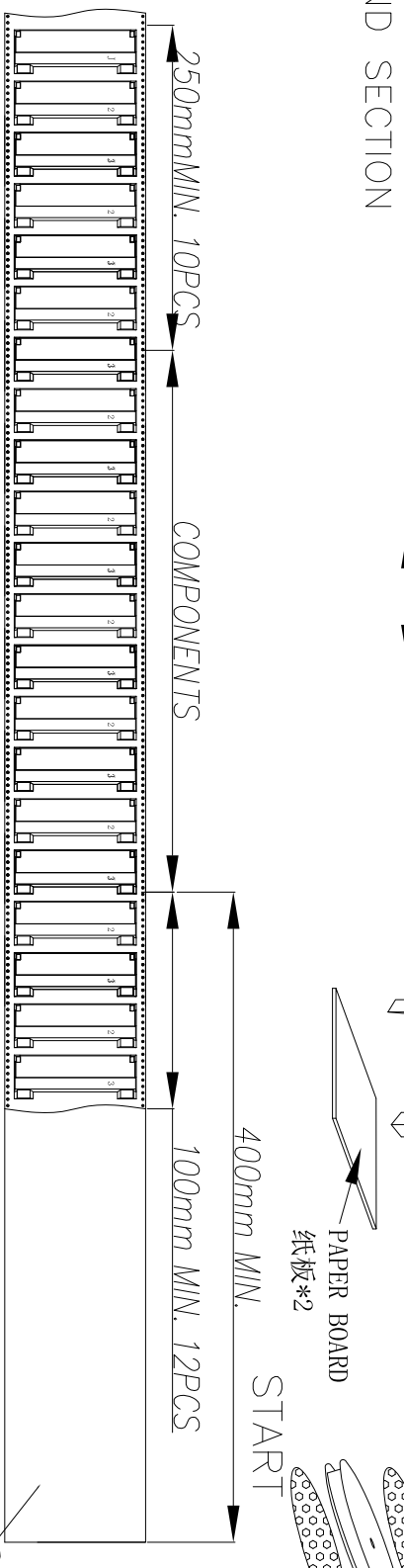
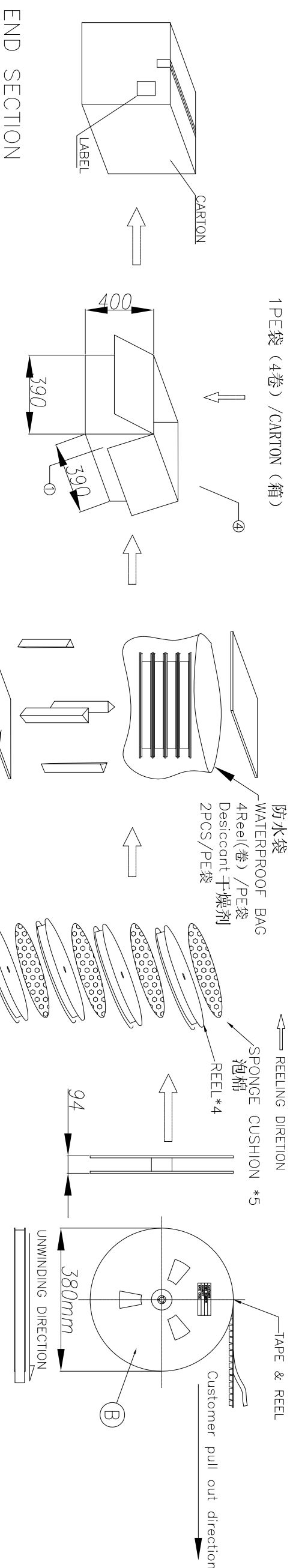
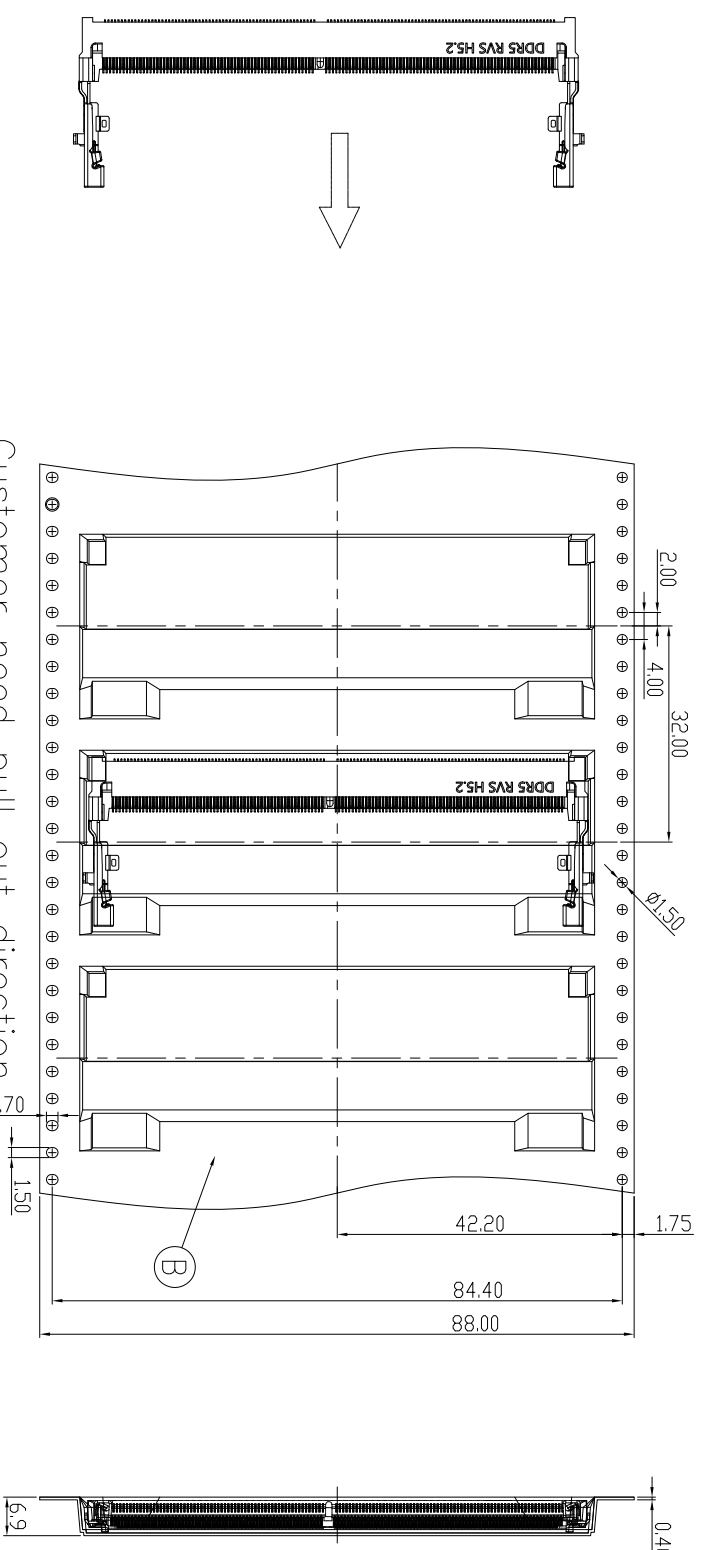

A	165°-180°
F	0.1N-1.3N

NOTES:

- 1.Quantity: 400PCS/Reel
- 2.Each plate needs vacuum packaging, and 2PCS desiccant is placed in the packaging bag

ITEM	MATERIAL	Q'TY	NOTE
⑤	WATERPROOF BAG	1	
④	SUPPORT BRACE	4	
③	REEL ASS'Y	4	
②	CARRIER TAPE	4	
①	CARTON	1	

GENERAL TOLERANCE DWG.NO. DDR003-SS401-08

PART.NO. DDR003-SS401-**

DRAWN DU 2023-06-14

UNIT mm

SCALE ND SCALE

REV. X.±0.50

B

TITLE

DDR5 S0 DIMM 262Pin(RVS) H5.20

CHECKED

UNIT

REV. X.±0.25

B

SHEET

4 DF 4

APPROVED

REV. X.X±0.15

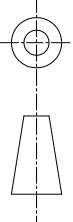

SHEET

4 DF 4

APPROVED